

# Paschke Online

**Designs Ink Publishing Article Archive and Research Library**

Chris A. Paschke, CPF GCF

## "Float Frames for Encaustic"

December 2009

In order to help prevent the warping of paintings on lightweight wood bars—stretchers or strainer--historically canvases have been placed in frames to add support for hanging. During the mid 20th century the display of unframed stretched canvases became very trendy and heavier strainer bars were used to support the canvases intended for display with no frame reinforcement. Such is the case with many of the paintings from the abstract expressionist era.

The practice of stripping was developed during that time in an attempt to help finish off the look of an unframed canvas. It is the application of thin wood strips 1/4" to 3/8" thick fitted against the painting along the outside edge of the painting to add support to a lightweight stretcher. This type of frame trim is also called a baguette (**photo 1**). They are sometimes mitered, but often butt joined and nailed directly into the strainer through the canvas. Unfortunately this type of frame offers little additional support and only serves as a slight visual improvement. Today's float frame has evolved from the baguette, with more support and exterior protection, while allowing for a float space between the outer moulding and the inner canvas (**photo 2**).



photo 1

Lattice strips are usually extended full top to bottom with the horizontal strips tucking inside.



photo 2

The float frame surrounds the canvas while allowing a gap between the frame and the canvas. The art is also attached at the back rather than nailed through the sides. This sample—photographed in a Chinese museum--has nearly a 1/2" float space.

Float frames are available in a number of styles, heights, and depths designed to accommodate a variety of canvas and hardboard cradle depths, and the art is attached at the back rather than nailed through the sides. For the sake of clarity in this article a standard float frame is an *L-shaped* moulding profile that supports the canvas from the back allowing for a variable space between the art and the side of the frame. A *step float* has a built-in stair step profile with a set float space set by the design of the profile. The frame *face* is the visible top width of the frame. The *float space* is the gap between the frame and canvas, cradle, or art panel, not necessarily the support platform. The *base* is the back width of the frame that the art actually rests on (**diagram 1**).

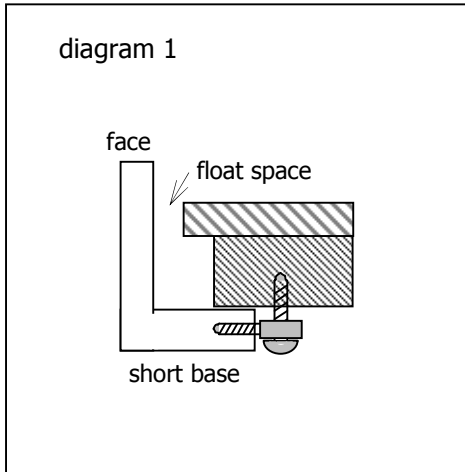

### Canvas vs. Encaustic

The standard float is used most often for stretched canvases and for cradled hardboards. Many believe the surface of a canvas should be aligned 1/16" to 1/8" just beneath the face of the frame with a 1/8" float space, though this is variable depending on the art and the illusion being created (**diagram 2**).

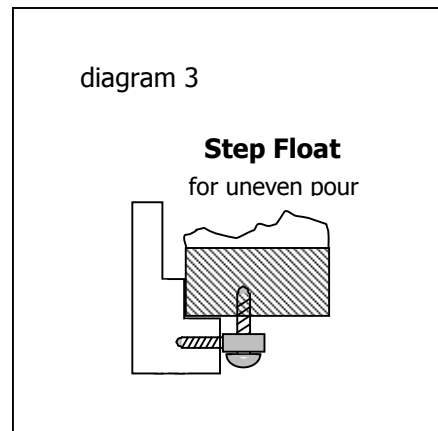
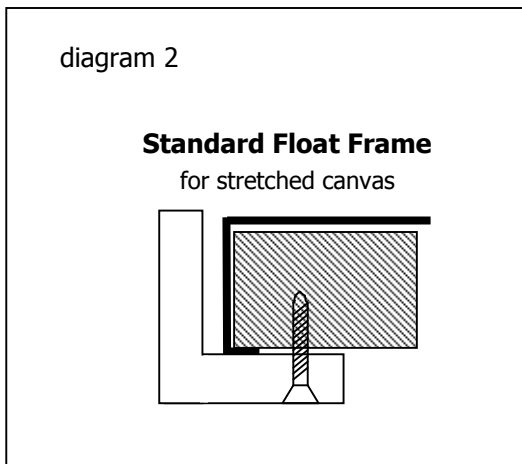

Encaustic artists often work on hardwood favoring Baltic birch, white maple, or even Masonite. High quality 1/4" Baltic panels are mounted atop a 3/4" birch wood perimeter creating a box called a cradle (**photo 3**). Commercially purchased lightweight boxes with narrower side strips may warp, but reinforced custom made panel boxes often prevent warping and eliminate the need for a formal picture frame once the wax painting is complete, like a gallery wrap. Commercial hardboard panels used for encaustic are available as thin as 1/8" and as thick as 3/8". The framing of these will vary greatly depending on the application of the medium.

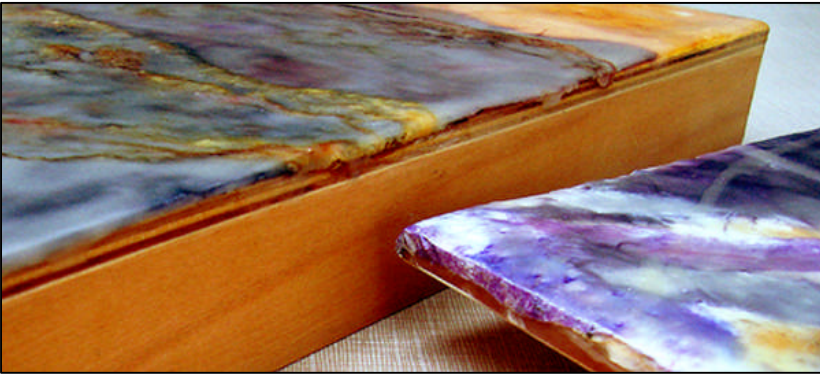

photo 3  
The top custom cradled panel is 1/4" Birch with 3/4" birch siding, right is a 1/4" Birch hardboard panel. Both are ready for framing and will require different float frame profiles.

### Float and Recess Spaces

Encaustic surfaces and edging dictate the type of float frame and the distances required from the frame face and the float space. When wax extends beyond the edges of the panel, a raised platform mount is required to protect the edges and deckle drips. The square edge panel could be fitted into a stepped profile if it were a thicker panel. The thin 1/4" panel requires a lifter as in diagram 1.

How deep is deep enough to be set back from the frame face? Pay attention to all areas of the wax or paint. If the setback is to be 1/32" it must be aligned from the highest point on the surface of the art. The depth, setback, or recess from the frame face is greater for encaustic art than for canvas, but in either case it shall always be set deep enough to protect the full surface of the art if the frame were laid face down on the table. The frame profile should be selected to accommodate the full depth of the art plus substrate, not just the substrate. In opposition, add platform lifters if the panel is too thin and sets back too far from the face. If 1/2" isn't adequate for the selected moulding add more. Traditional stretched canvas recesses are 1/32" to 1/16", with a float space of 1/32" to 1". For encaustic the recesses are 1/8" to 1/2" with a float space commonly 3/8" to 1" depending on the size of the panel in an L frame.

Watch the proportions of the face width to the float space. As when designing for mats and mat decoration it is important to pay attention to repetitious measurements. If the face of the profile is 1/4", the float space should be less than or greater than 1/4". The deckle drip art (UL) in **photo 4** has a float space of 1/16" at some points and nearly 1/4" at others, but the variation keeps it interesting. The square edge piece (R) is fairly evenly spaced with a 1/4" face and 3/16" float space. The uneven pour (LL) needed to showcase the wax depth so it has a 5/16" float space with uneven surface.



photo 4  
(Top) The deckle drip has a float space of 1/16" at some points and nearly 1/4" at others. The square edge piece (R) is fairly evenly spaced with a 1/4" face and 3/16" float space. The uneven pour needed to showcase the wax depth so a 5/16" float space was used.

### Assorted Profiles

There are dozens of float frame profiles and depths available with numerous possibilities. Stepped profiles vary by float space and height of the frame. L-shaped profiles are available as short base or long base and in numerous heights. Stocking two or three float mouldings may not meet your design requirements, because if the float space in a step moulding is not wide enough for an encaustic, or the profile height is either too short to protect the art or is too tall and overpowers the canvas they will never work. In fact different profiles and depths may be needed for encaustic, canvas, and/or commercial hardboards. It would not be unreasonable to stock two dozen or more float frame profiles and colors.

One final consideration, long base profiles allow for screwing through the frame directly into a strainer or panel, while short base profiles often require an eye screw mounted horizontally into the moulding base with a vertical round head screw through it into the panel. Refer to the diagrams for samples.

END

Copyright © 2009 Chris A. Paschke

For more articles on mounting basics look under the mounting section in Articles by Subject.

Additional information on all types of mounting and creative applications in:

*The Mounting and Laminating Handbook, Second Edition, 2002,*

*The Mounting And Laminating Handbook, Third Edition, 2008,*

*Creative Mounting, Wrapping and Laminating, 1999.*

Chris Paschke, CPF GCF

Designs Ink

Tehachapi, CA 93561

P 661-821-2188

chris@designsinkart.com

<http://www.designsinkart.com/library.htm>